

# One-door Access Controller

User Manual v2.0

## 1. Specifications:

### 1.1 Technical parameters:

NO	Item	Value
1	Operating voltage	DC 12V±10%
2	Operating current	< 100mA
3	Dimensions	140*45*17mm
4	Weight	110g
5	Ambient temperature	-10℃—60℃
6	Relative humidity	20%—80%
7	Storage	1000users
8	Card type (alternative)	EM(ID) card(IC card for options)
9	Card reading distance	1—15CM

### 1.2 Factory Default:

<b>Programming Password</b>	123456	<b>Common Access Password</b>	None
<b>Backlight</b>	Auto (for options)	<b>Relay Unlock output</b>	5 Seconds
<b>W26 port</b>	Input (for options)	<b>Security mode</b>	OFF
<b>Open mode</b>	Card or Access Password Access Password include Private Access Password (PIN) and Common Access Password		

### 1.3 Light and Sound indicates:

#### Light: red and green

Light Description	Access control status
Red light flash every 1 sec (Slow flash)	Holding state
Red light is always ON	Programming state
Green light is always ON within Open time	Unlocking state
Green light flash every 0.5sec (Fast flash)	Pending further action

#### Sound: buzz

Description	Indicates
1 short buzz	Valid input
3 short buzz	Invalid input
1 long buzz	Program success
Continuous long buzz	Restoring factory programming passwords

## 2. Installations Guide:

NO	Mark	Color	Function
1	+12V	Red	Power+
2	GND	Black	Power-
3	DATA0	Green	WG DATA0
4	DATA1	White	WG DATA1
5	BELL+	Blue	BELL
6	BELL-	Purple	BELL
7	PUSH+	Yellow	5V Voltage output
8	OPEN	Brown	Door Release
9	LOCK+	Orange	LOCK+(12V)
10	LOCK-	Grey	LOCK-

### Wiring diagram:

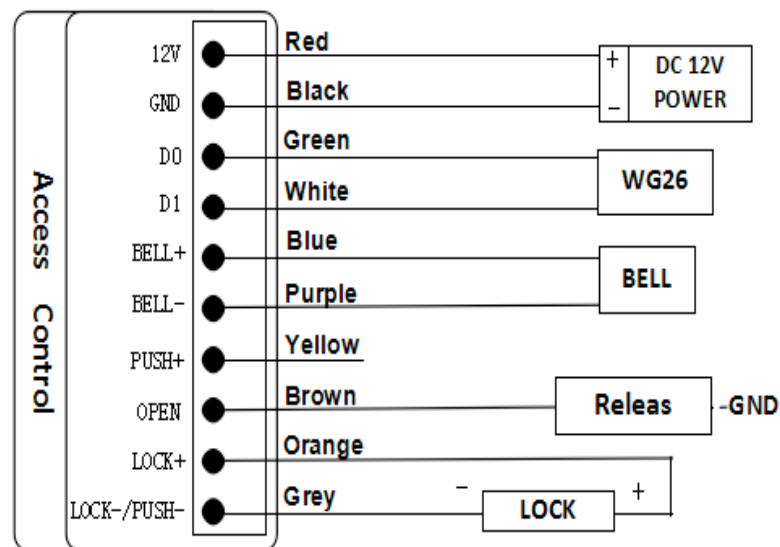

Note:

1、Select LOCK terminal to NC or NO by Jumper S2

2、When select NO, Unlock Time should be set as Instant Output (reference 3.1) to avoid

### 3 Programming Guide

Programming Password Default: 123456,

#### 3.1 Detailed Programming Guide:

all password can be 3~6 digits

Purpose		Operation				Remark	
Basic Function	Change Programming Password	#	Programming Password	#	0 new Programming Password	#	If Programming Password lost, perform 3.2 to reset to Factory Default (123456).
			New Programming Password	#			
	Add user card	#	Programming Password	#	1 read card	#	If add multi cards, read cards continuously
	Set Common Access Password	#	Programming Password	#	21 new Common Access Password	#	Common Access Password is only one. Open method: Common Access Password
	Delete all users	#	Programming Password	#	40 0000	#	Delete all cards and PIN except Common Access Password
	Delete user by read card	#	Programming Password	#	41 read card	#	If delete multi cards, read cards continuously
Expand Function	Add Private Access Password(PIN)	#	Programming Password	#	22 PIN	#	PIN can be more, Unlock door method: PIN
	Add card by input card No.	#	Programming Password	#	23 input card No.	#	Card No. is 10-digit or 8-digit, machine auto-identify
	Add multi-card by input card No. zone	#	Programming Password	#	24 input start card No. card Qty	#	Card Qty is 4-digit (If one-time add twenty cards, input 0020)
	Add "card +PIN"	#	Programming Password	#	3 read card PIN	#	If modify PIN, see 3.5
	Delete user by input User ID No.	#	Programming Password	#	42 input User ID No.	#	About User ID No. see 3.4
	Delete user by input card No.	#	Programming Password	#	43 input card No.	#	Card No. is 10-digit or 8-digit, machine auto-identify
	Delete user by input PIN	#	Programming Password	#	44 input PIN	#	PIN is 3~6 digits.
	Delete all PIN users	#	Programming Password	#	45 1111	#	Use to PIN users (Do not include Card users and Card +PIN users)
	Change Open time	#	Programming Password	#	5 XX	#	XX can be 2-digit, and the max. is 99. If input 00, the signal output time is 0.2 Secs.
	Set Open mode	#	Programming Password	#	6 XX	#	XX can be 01(only card)/ 02(card or Access Password)/ 03(card+PIN)
	Reader setting (For options)	#	Programming Password	#	6 04	#	The machine can be used for reader(W26 output)
	Security function Setting	#	Programming Password	#	7 XX	#	XX can be 01/ 02( Security function OFF/ON) and 03/04(Anti-dismantle alarm OFF/ON)
	Anti-dismantle Alarm setting(For options)	Remark: Security Function ON means System would be locked for 5 Minutes if continue to read illegal card or input wrong Access Password for 10 times.					
	Backlight setting(For options)	#	Programming Password	#	8 XX	#	XX can be 01/02/03 (Normal ON / Normal OFF / Auto)
	Reset Factory Default	#	Programming Password	#	8 99	#	Except Programming Password and Manager Card
Set Manager Card	#	Programming Password	#	91 read MAC read MDC	#	First read card is Manager Add Card and Second read card is Manager Delete Card.	

#### 3.2 To reset to Factory Programming Password (123456)

Step1、 Turn off power and connect bin 2&3 of RST(S1).

Step2、 Turn on power and buzzer gives 3 long buzz with green light flash fast.

If need to set Manager Card, now read two empty cards first one as Manager Add Card and

Second one as Manager Delete Card with red light flashing and continuous short buzz .

Step3、 Turn off power, disconnect bin2&3 and connect bin 1&2 of RST.

Step4、 Turn on power again.

#### 3.3 How to use Manager Card – MAC&MDC

To add a card user in standby mode:

To delete a card user in standby mode:

To delete all users in standby mode:

Remark: User cards can be added or deleted continuously.

#### 3.4 User ID No. explain

User ID is auto-generating 4-digit number started at 0001. The number increases with adding user one by one and ignores deleting user. Common Access Password has no ID.

#### 3.5 How to change PIN (When open mode: card+ PIN)

After reading card and input corresponding PIN to open the door, within 5 seconds, long press  until the green lights flash fast. and then input    , new PIN changed successfully with a long buzz.